

RICOH Pro L4130/L4160 Print Guide

Thank you for purchasing our printer cutter RICOH Pro L4130/L4160.
This "Print Guide" explains the printing method using RICOH Pro L4130/L4160 and the attached software RIP [RICOH Software RIP] and items to be checked/set before printing.

First, confirm the following items:

Before printing, the preparation for RICOH Pro L4130/L4160 and the software RIP [RICOH Software RIP] is required.

First, prepare the followings:

About system configuration (Refer to P. 2)

The explanation of the system configuration to print is described.

Prepare RICOH Pro L4130/L4160 (Refer to P. 3)

To use RICOH Pro L4130/L4160, the items below are explained:

- Connect the PC in which the software [RICOH Software RIP] has been installed with RICOH Pro L4130/L4160.
- Turn on the power supply.
- Depending on the media to be set, adjust the print head height etc.
- Set the media.
- Perform test printing to check whether there is no nozzle clogging etc.
- Correct the feeding rate of media.
- Correct the ink drop position.

Prepare the RICOH Software RIP (Refer to P. 4)

The preparation of the software [RICOH Software RIP] is explained.
For the installation method, refer to the manual of the RICOH Software RIP.

The printing method using a sample is explained.

Here, the printing method using a sample image included in the attached CD.

Perform printing (Refer to P. 5)

Some typical questions are described.

Typical questions (Refer to P. 7)

First, confirm the following items:

About system configuration

Instruct to print the printing data created with the application such as Illustrator or Photoshop etc. from the PC in which the attached RICOH Software RIP has been installed.

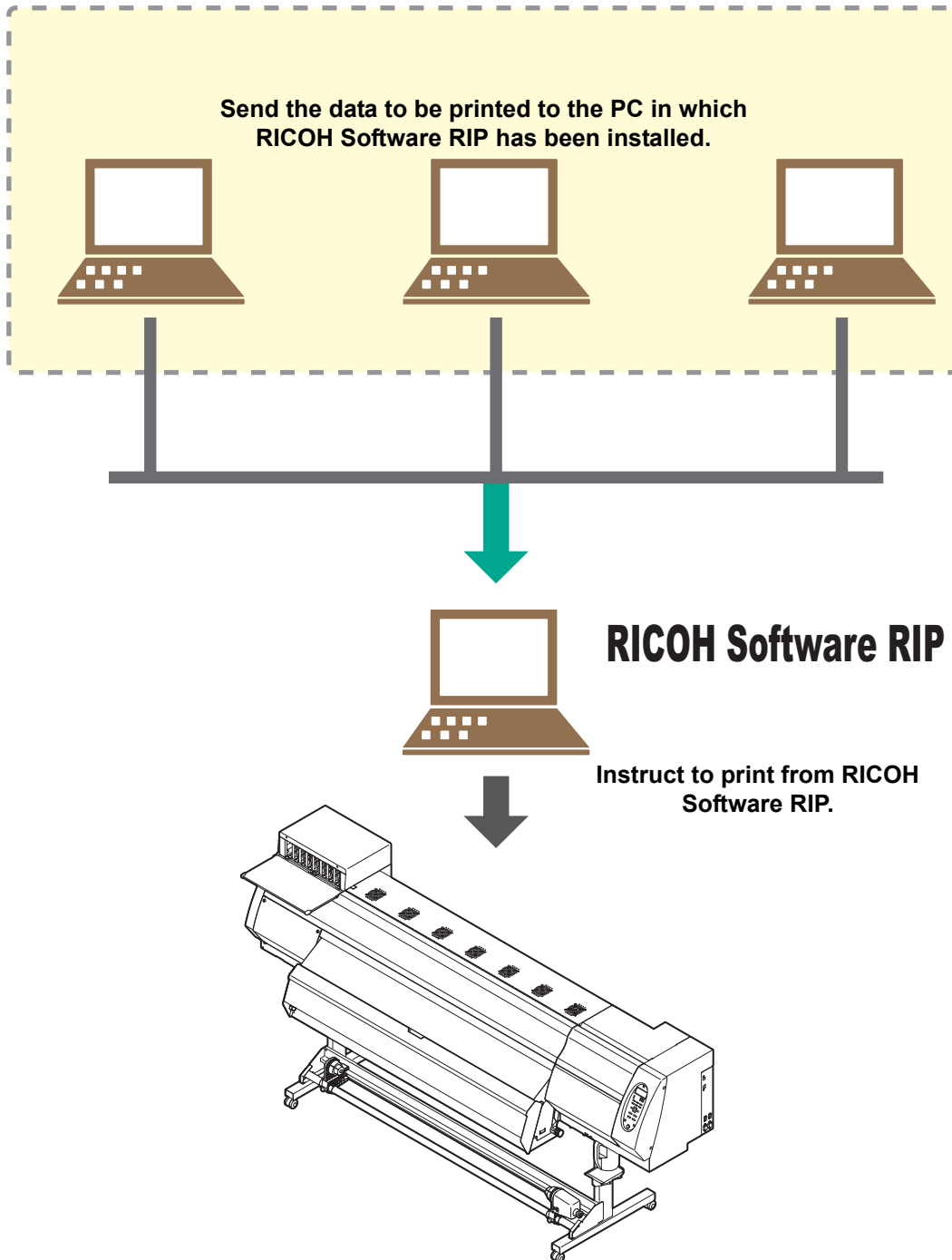

Prepare RICOH Pro L4130/L4160

Following the procedures below, prepare RICOH Pro L4130/L4160.

1. Connect a PC in which the attached RICOH Software RIP is installed with RICOH Pro L4130/L4160.

- For details, refer to [P.1-10 of RICOH Pro L4130/L4160 Operation Manual](#).

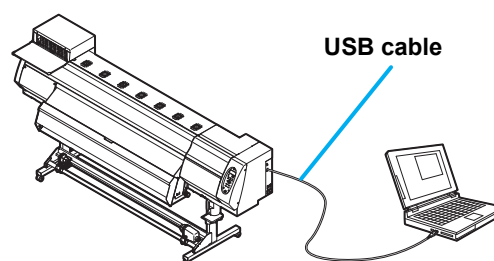

2. Turn on the power supply of RICOH Pro L4130/L4160.

- For details, refer to [P.2-3 of RICOH Pro L4130/L4160 Operation Manual](#).

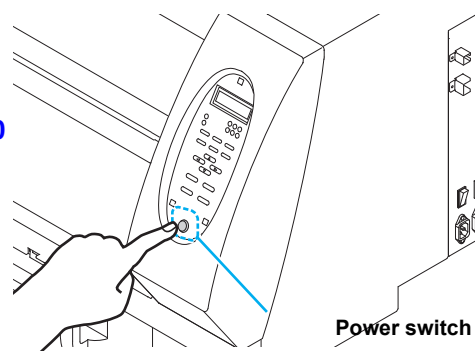

3. Before setting a media, check the height of print head.

- For details, refer to [P.2-5 of RICOH Pro L4130/L4160 Operation Manual](#).
- Adjust the Height-adjusting lever depending on the media to be used.

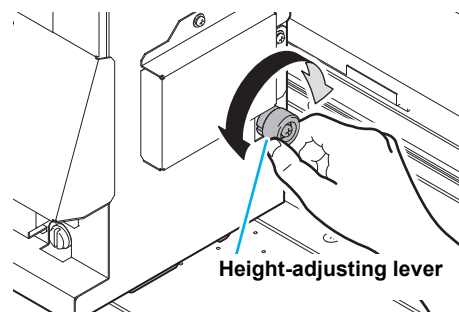

4. Set the media.

- When setting the roll media : [P.2-8 to 12 of RICOH Pro L4130/L4160 Operation Manual](#)
- When setting the leaf media : [P.2-14 to 15 of RICOH Pro L4130/L4160 Operation Manual](#)

5. Perform a test printing.

- Check if discharging defect such as nozzle clogging exists or not.
- For details, refer to [P.2-20 to 21 of RICOH Pro L4130/L4160 Operation Manual](#).

6. Perform a feed correction.

- Correct the feeding rate of media.
- For details, refer to [P.2-23 to 24 of RICOH Pro L4130/L4160 Operation Manual](#).

7. Perform a test dot position correction.

- Correct the ink drop position.
- For details, refer to [P.2-25 to 26 of RICOH Pro L4130/L4160 Operation Manual](#).

Prepare the RICOH Software RIP

Check that the attached software RIP [RICOH Software RIP] is prepared.

1. Check if the attached RICOH Software RIP is installed.

- If it is installed, the icon on the right is displayed on the PC desktop.
- For the installation, refer to [Installation Guide of the attached RICOH Software RIP](#).



2. Check the connection with RICOH Pro L4130/L4160.

- (1) Is the power supply of RICOH Pro L4130/L4160 turned ON?
- (2) Is the PC in which the attached RICOH Software RIP is installed connected with RICOH Pro L4130/L4160?

3. Register the printer in the attached RICOH Software RIP.

- For print in RICOH Pro L4130/L4160, the registration of the printer into the attached RICOH Software RIP is required.
- If you have already registered a printer, you can skip this step. Proceed to ["Perform printing"](#).

- (1) Double click  to start the RICOH Software RIP.

- The main window of the RICOH Software RIP is displayed.
- If no printer is registered, the [Printer Management...] window appears. In this case, proceed to step (3).

- (2) From the menu, select [Environments], and then [Printer Management...].
 - The [Printer Management...] window appears.

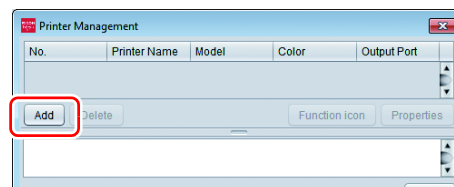

- (3) Click [Add].
 - The [Printer setting] window appears.

- (4) Set the printer information.
(The setup procedure described below assumes that RICOH Pro L4160 is connected. Set the printer information in the following order:)

- Output Port : USB2.0
- Available Printers : Select Pro L4160.
- Model : RICOHProL4000
- Color : Select depending on the device.
- Printer Name : Enter "4160".
(For an ink set, the information retrieved from the printer is displayed.)

- (5) Click [OK].
 - The confirmation screen is displayed. Clicking [OK] starts the registration of the printer.
 - The [Do you create the hot folder and printer driver?] confirmation window appears. If you want to create them, click [Yes]. (You can also create them at a later time.)

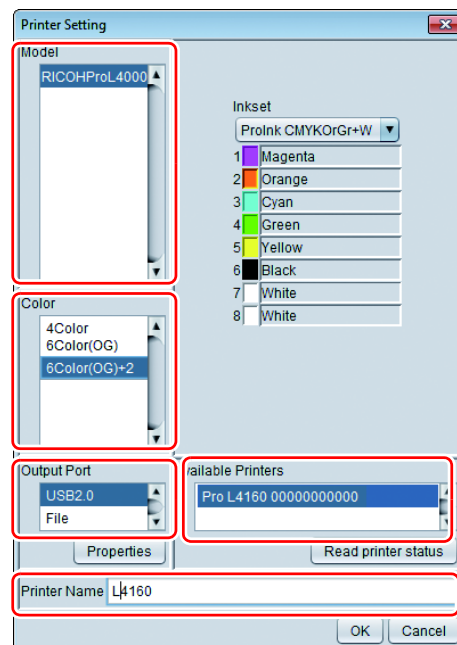

Perform printing

Here, the printing method using a sample image included in the CD of the JV 34 Operation Manual.



- Check **P. 2 to P. 4** “**First, confirm the following items:**” without fail before creating a seal/a sticker.

1. Double-click to start the attached RICOH Software RIP.

- The main window of the attached RICOH Software RIP is displayed.

2. Set the CD of RICOH Pro L4130/L4160 Operation Manual into the disk drive.

3. Click [Print Guide / Sample data].

- The “Print Guide and Sample Data” dialog is displayed.

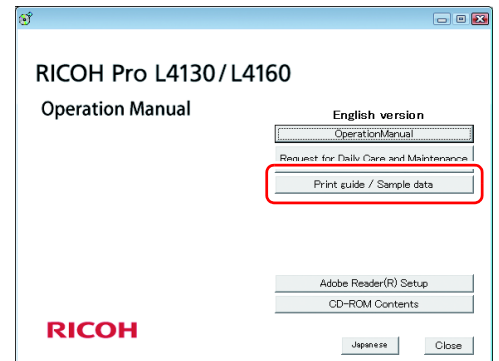

4. To select the data you want to print from the RICOH Software RIP, select [File], and then [Open] from the menu.

- The “Select file name to print” window appears.

5. Select the file to be printed, and click [Open].

- If more than one printer is registered, select [ProL4160] from [Printer Name].
- For details on the Favorites setting, see the RICOH Software RIP Reference Guide.
- The file is loaded. The loaded file is displayed on the [ProL4160] tab in the main window.

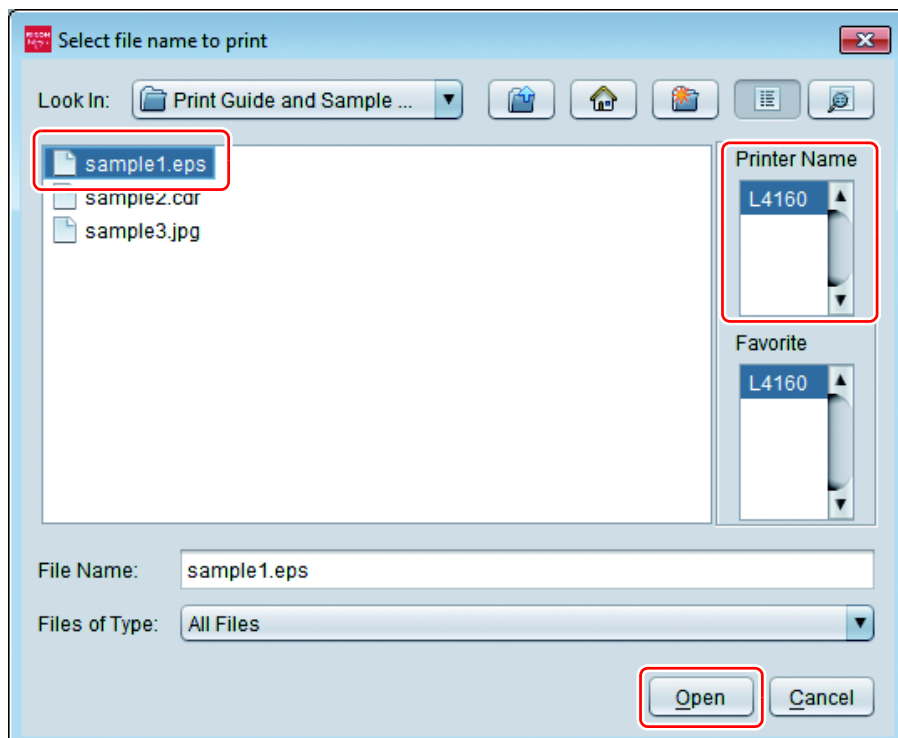

6. Select the file loaded into the [ProL4160] tab.

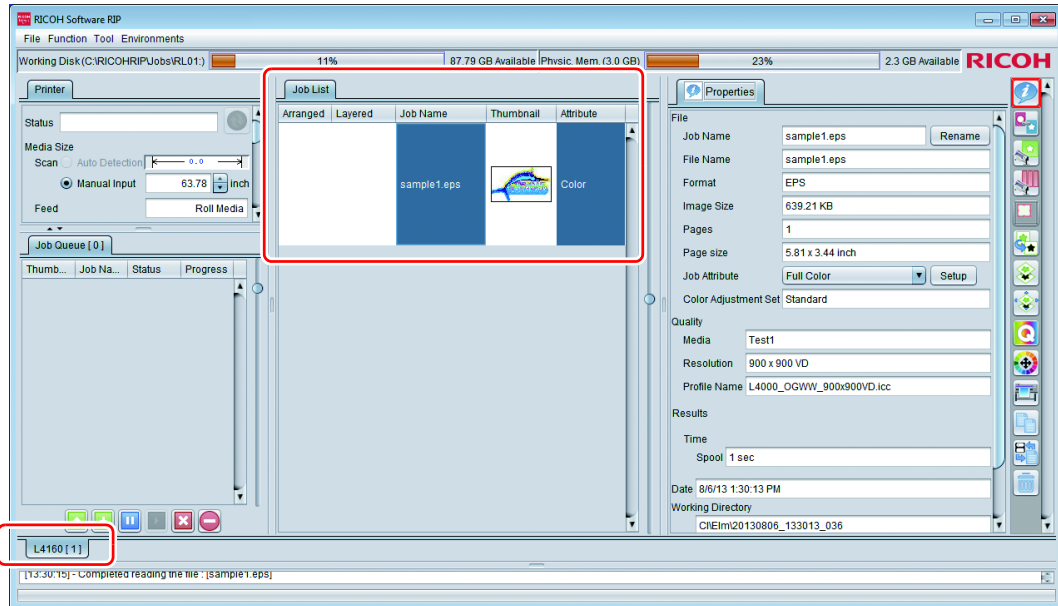

7. To check or edit the settings, from [Function icons] displayed in the right side of the window, select the icons shown below.

- For details about each function icon, see the attached RICOH Software RIP Reference Guide.

(1) To specify the enlargement, reduction, or copy setting, select (General Print).

(2) To select a profile that matches the medium or ink set installed in RICOH Pro L4130/4160, select (Quality).

8. To print a file, select (Execution) from the [Function icons] displayed in the right side of the window.

- (1) Select [RIP & Print] or [Immediate Print].
- (2) Click [Start].



- If you have replaced a medium in RICOH Pro L4130/4160, perform the following steps to acquire the width of the medium from the printer.

1. In the media window, select the [ProL4160] tab.

2. In the [Printer] section, click .

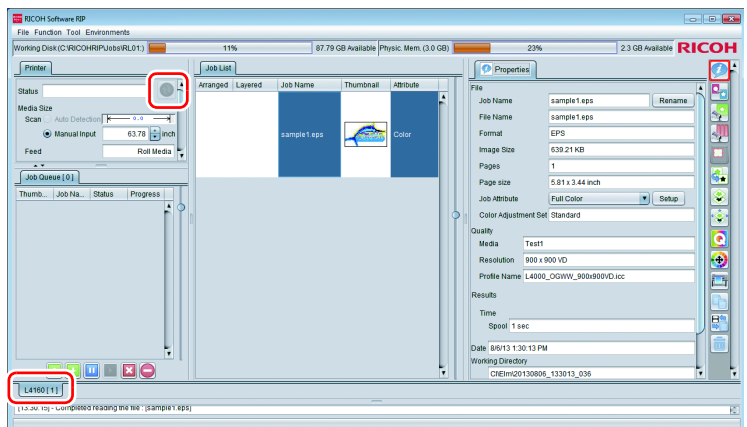

Typical questions

The answers to the questions/ the troubles frequently asked by the customer are provided.

About errors

● “Replace a WIPER” is displayed

Check the wiper and if there are any scratches at the apical end of the wiper film, replace the wiper by following the [Chapter 4 “Replacing the wiper” of the OPERATION MANUAL](#).

● “WASTE TANK” is displayed

The waste ink tank is nearly full. Replace the waste ink tank by following the procedures in [Chapter4 “If a Waste Ink Tank Confirmation Message Appears” of the OPERATION MANUAL](#). (Even if you replace the waste ink tank, the display does not disappear.)

Supplied items

Purchase them in a distributor in your district or our office.

Name of part	Specifications	Part codes	Remarks
Pro Wiper kit Type A	Including 10	841906	
Pro Waste Ink Bottle Type A	One	841907	
Pro Cutter Blade Type A	One	841908	
Pro Absorbent Sponge kit Type A	3 set	841910	
Pro Flushing Cartridge Type A	220ml	For North America : 841971 For Europe : 841974	Dedicated for rear surface set of main body
Pro Maintenance kit Type A	200ml	For North America : 841970 For Europe : 841973	
Pro Filter kit Type A		841912	

RICOH