

# Operating Instructions Printer / Scanner Reference

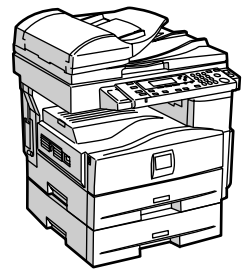

- 
- 1** Getting Started
  - 2** Installing the Software
  - 3** Using the Printer Function
  - 4** Using the TWAIN Scanner Function
  - 5** Troubleshooting
  - 6** Appendix

---

Read this manual carefully before you use this machine and keep it handy for future reference. For safe and correct use, be sure to read the Safety Information in the "Copy Reference" before using the machine.

## Introduction

This manual contains detailed instructions and notes on the operation and use of this machine. For your safety and benefit, read this manual carefully before using the machine. Keep this manual in a handy place for quick reference.

## Important

Contents of this manual are subject to change without prior notice. In no event will the company be liable for direct, indirect, special, incidental, or consequential damages as a result of handling or operating the machine.

Do not copy or print any item for which reproduction is prohibited by law.

Copying or printing the following items is generally prohibited by local law:

bank notes, revenue stamps, bonds, stock certificates, bank drafts, checks, passports, driver's licenses.

The preceding list is meant as a guide only and is not inclusive. We assume no responsibility for its completeness or accuracy. If you have any questions concerning the legality of copying or printing certain items, consult with your legal advisor.

## Caution:

Use of controls or adjustments or performance of procedures other than those specified in this manual might result in hazardous radiation exposure.

Two kinds of size notation are employed in this manual. With this machine refer to the metric version.

## Trademarks

Microsoft®, Windows® and Windows NT® are registered trademarks of Microsoft Corporation in the United States and/or other countries.

Other product names used herein are for identification purposes only and might be trademarks of their respective companies. We disclaim any and all rights to those marks.

The proper names of the Windows operating systems are as follows:

- The product name of Windows® 98 is Microsoft® Windows® 98
- The product name of Windows® Me is Microsoft® Windows® Millennium Edition (Windows Me)
- The product name of Windows® 2000 are as follows:
  - Microsoft® Windows® 2000 Advanced Server
  - Microsoft® Windows® 2000 Server
  - Microsoft® Windows® 2000 Professional
- The product name of Windows® XP are as follows:
  - Microsoft® Windows® XP Professional
  - Microsoft® Windows® XP Home Edition
- The product names of Windows Server™ 2003 are as follows:
  - Microsoft® Windows Server™ 2003 Standard Edition
  - Microsoft® Windows Server™ 2003 Enterprise Edition
  - Microsoft® Windows Server™ 2003 Web Edition

## Notes:

Some illustrations in this manual might be slightly different from the machine.

Certain options might not be available in some countries. For details, please contact your local dealer.

# Manuals for This Machine

The following manuals describe the operational procedures of this machine. For particular functions, see the relevant parts of the manual.

## **Note**

- Manuals provided are specific to machine type.
- Adobe Acrobat Reader is necessary to view the manuals as a PDF file.

## ❖ **General Settings Guide**

Provides an overview of the machine and describes System Settings (paper trays, Key Operator Tools, etc.), and troubleshooting.

## ❖ **Network Guide**

Describes procedures for configuring the machine and computers in a network environment.

## ❖ **Copy Reference**

Describes operations, functions, and troubleshooting for the machine's copier function.

## ❖ **Printer/Scanner Reference (this manual)**

Describes system settings, functions, troubleshooting and operations for the machine's printer and scanner function.

## ❖ **Other Manuals**

- Manuals for This Machine
- Safety Information
- Quick Reference Copy Guide
- Quick Reference Printer / Scanner Guide

# TABLE OF CONTENTS

Manuals for This Machine .....	i
How to Read This Manual .....	1

## 1. Getting Started

---

<b>Control Panel</b> .....	<b>3</b>
Reading the Display and Using Keys .....	4
<b>Connecting the Machine</b> .....	<b>5</b>
Requirements.....	5
Connecting the machine to the host using a USB cable .....	5

## 2. Installing the Software

---

<b>Auto Run</b> .....	<b>7</b>
<b>Installing the Printer Driver</b> .....	<b>8</b>
<b>Installing the TWAIN Driver</b> .....	<b>9</b>
<b>Software Supplied on CD-ROM</b> .....	<b>10</b>
DDST Driver.....	10
DDST TWAIN Driver .....	10

## 3. Using the Printer Function

---

<b>Printer Features Menu</b> .....	<b>11</b>
<b>Adjusting Printer Features</b> .....	<b>12</b>
<b>Printer Features Parameters</b> .....	<b>13</b>
Paper Input.....	13
List/Test Print .....	13
Maintenance.....	14
System .....	15
Host Interface.....	16
<b>Setting Paper on the Bypass Tray</b> .....	<b>17</b>
Setting the paper size .....	18
Setting custom size paper.....	19
Setting thick paper or OHP transparencies.....	20
Setting envelopes.....	21
<b>Setting Up the Printer Driver and Canceling a Print Job</b> .....	<b>22</b>
Windows 98SE / Me - Accessing Printer Properties .....	22
Windows 2000 / XP and Windows Server 2003 - Accessing Printer Properties .....	23
Canceling a Print Job .....	24

## 4. Using the TWAIN Scanner Function

---

<b>TWAIN Scanner</b> .....	<b>27</b>
<b>Preparation for Using the Network TWAIN Scanner</b> .....	<b>28</b>
TWAIN Scanner Screen.....	28
<b>Setting Originals</b> .....	<b>29</b>
Placing Originals .....	29
<b>Scanning Originals</b> .....	<b>32</b>

**5. Troubleshooting**

---

**The Printer Function**..... **33**  
    Error & Status Messages on the Display ..... 33  
    The Machine Does Not Print ..... 36  
    Other Printing Problems ..... 38  
**The Scanner Function** ..... **40**  
    When Scanning Is Not Performed as Expected ..... 40  
    When an Error Message Appears on the Client Computer ..... 41

**6. Appendix**

---

**The Printer Function**..... **43**  
    Collate ..... 43  
**The Scanner Function** ..... **44**  
    Relationship between Resolution and File Size ..... 44  
**Specifications**..... **45**  
    Printer..... 45  
    Scanner..... 45  
**INDEX**..... **46**



# How to Read This Manual

---

## Symbols

---

In this manual, the following symbols are used:

### **WARNING:**

This symbol indicates a potentially hazardous situation which, if instructions are not followed, could result in death or serious injury.

### **CAUTION:**

This symbol indicates a potentially hazardous situation which, if instructions are not followed, may result in minor or moderate injury, or damage to property.

\* The statements above are notes for your safety.

### **Important**

If this instruction is not followed, paper might misfeed, originals might be damaged, or data might be lost. Be sure to read this.

### **Preparation**

This symbol indicates prior knowledge or preparation is required before operation.

### **Note**

This symbol indicates precautions for operation, or actions to take after mal-operation.

### **Limitation**

This symbol indicates numerical limits, functions that cannot be used together, or conditions in which a particular function cannot be used.

### **Reference**

This symbol indicates a reference.

[   ]

Keys and buttons that appear on the computer's display.

[   ]

Keys that appear on the machine's display.

[   ]

Keys built into the machine's control panel.

[   ]

Keys on the computer's keyboard.





# 1. Getting Started

## Control Panel

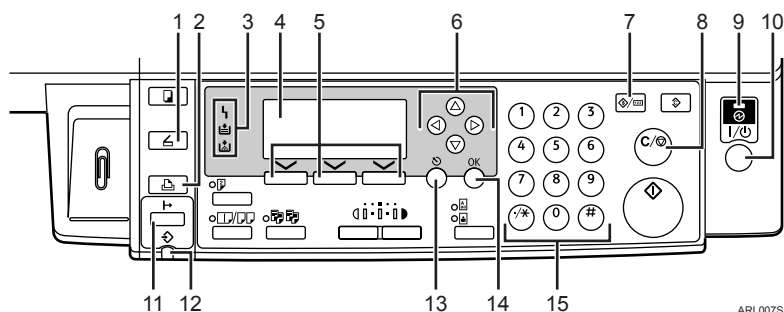

### 1. [Scanner] key

Press to activate the scanner function.

### 2. [Printer] key

Press to activate the printer function.

### 3. Indicators

Displays errors and machine status.

: Error indicator. See *Network Guide* and *General Settings Guide*.

: Load Paper indicator. See *Copy Reference*.

: Add Toner indicator. See *Copy Reference*.

### 4. Display

Displays operation status and messages.

### 5. Selection keys

Correspond to items on the display. Press to select the corresponding item.

### 6. Scroll keys

Press to select an item.

: scroll upward

: scroll downward

: scroll right

: scroll left

### 7. [User Tools/Counter] key

Press to change default or operation parameters according to requirement.

### 8. [Clear/Stop] key

Clear: clears an entered numeric value.

### 9. Main power indicator and On indicator

The main power indicator lights when the main power switch is turned on. The On indicator lights when the operation switch is turned on.

### 10. Operation switch

Press to turn the power on. The On indicator lights. To turn the power off, press again.

### Note

 This key is inactivate during printing or while setting printer defaults.

### 11. [Online] key

Press to switch the printer between on-line and offline.

### 12. Data In indicator

Blinks while the printer is receiving data from a computer or printing. Lit when preparing to print.

### 13. [Escape] key

Press to cancel an operation or return to the previous display.

### 14. [OK] key

Press to set a selected item or entered numeric value.

### 15. Number keys

Press to enter numeric values.

## Reading the Display and Using Keys

This section explains how to read the display and use the selection keys on the initial display.

### Note

- The copy display is set as the default screen when the machine is turned on. You can change the settings in **[System Settings]**. See *General Settings Guide*.

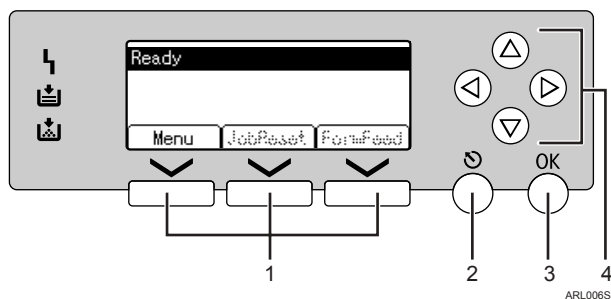

### 1. Selection keys

Correspond to the function items at the bottom line on the display.

Example: Basic screen

When the instruction "press **[JobReset]**" appears in this manual, press the center selection key.

### 2. [Escape] key

Press to cancel an operation or return to the previous display.

### 3. [OK] key

Press to set a selected item or entered numeric value.

### 4. Scroll keys

Press to move the cursor in each direction, step by step.

When the **[▲]**, **[▼]**, **[▶]**, or **[◀]** key appears in this manual, press the scroll key of the same direction.

# Connecting the Machine

## Reference

For details about connection using Ethernet, see "Connecting the Network Cable to the Network", *Network Guide*.

## Requirements

Before using this machine, make sure all environmental and electrical requirements are met. Connect the machine to the host computer using the USB port or network interface unit.

Make sure all cables, connectors, and electrical outlets necessary for attaching the machine to the host computer or network are close at hand.

## Connecting the machine to the host using a USB cable

You can connect the machine to the host computer using a USB cable.

Follow the procedure below to connect the machine to the host computer using a USB cable.

- 1** Connect the USB 2.0 cable to the USB port on the right side of the machine's back cover.

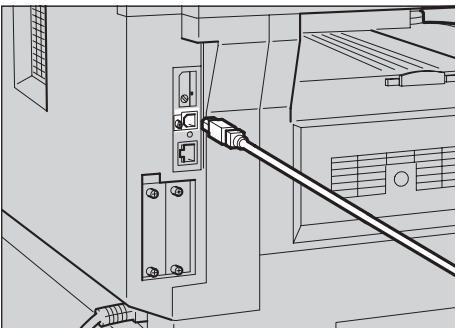

ARL0085

- 2** Connect the other end to the USB port on the host computer.

The machine and computer are now connected. The printer driver and TWAIN driver must be installed next. For details about how to install the printer driver and TWAIN driver, see p.8 "Installing the Printer Driver" and p.9 "Installing the TWAIN Driver".

## Note

- If USB 2.0 is used with Windows 98 SE/Me, only speeds equivalent to those of USB 1.1 are possible.



# 2. Installing the Software

This manual assumes you are familiar with general Windows procedures and practices. If you are not, see the operating instructions that come with Windows for details.

## Auto Run

Inserting the CD-ROM into the CD-ROM drive starts the installer automatically. The installer helps you install the printer drivers and software easily.

### Note

- When “plug and play” starts, click **[Cancel]** in **[New Hardware Found]**, **[Device Driver Wizard]** or **[Found New Hardware Wizard]** dialog box, and then insert the CD-ROM. The **[New Hardware Found]**, **[Device Driver Wizard]** or **[Found New Hardware Wizard]** dialog box appears depending on the version of Windows 98SE / Me / 2000 / XP or Windows Server 2003.
- Auto Run may not work with certain operating system settings. If this happens, launch "Setup.exe" on the CD-ROM root directory.
- To disable Auto Run, press the left **[SHIFT]** key when inserting the CD-ROM into the drive and keep it pressed until the computer finishes reading from the CD-ROM.

### Limitation

- Under Windows 2000 / XP or Windows Server 2003, installing software using Auto Run requires Administrator permission. To install software using Auto Run, log on using an account that has Administrator's permission.

## Installing the Printer Driver

To use the printer function, you must first install the printer driver from the supplied CD-ROM.

**1** Quit all applications currently running.

**2** Insert the CD-ROM into the CD-ROM drive.

The driver installer starts.

**3** Select an interface language, and then click **[OK]**.

The default interface language is English.

**4** Click **[DDST Printer Drivers]**.

The DDST Printer Drivers installer starts.

**5** The software license agreement appears in the **[License Agreement]** dialog box. After reading through its contents, click **[I accept the agreement.]**, and then click **[Next >]**.

**6** Follow the instructions on the display to install DDST Printer Drivers.

If you are required to restart the computer after installing DDST Printer Drivers, restart the computer.

### Note

The printer driver has been installed, plug and play is enabled, and the icon of the printer connected to the "USB" port is added to the **[Printers]** or **[Printers and Faxes]** window.

For details about using the printer function via Ethernet under Windows 98SE / Me, see "Using the Printer Function", *Network Guide*.

For details about using the printer function via Ethernet under Windows 2000 / XP / Server 2003, see "Using the Printer Function", *Network Guide*.

# Installing the TWAIN Driver

To use the scanner function, you must first install the TWAIN driver on the supplied CD-ROM.

**1** Quit all applications currently running.

**2** Insert the CD-ROM into the CD-ROM drive.

The driver installer starts.

**3** Select an interface language, and then click **[OK]**.

The default interface language is English.

**4** Click **[DDST TWAIN Driver]**.

The DDST TWAIN Driver installer starts.

**5** Click **[Close]**.

## Software Supplied on CD-ROM

This section explains the software on the CD-ROMs supplied with the printer option.

---

### DDST Driver

---

2

The DDST drivers are included on the CD-ROMs that comes with this machine. These drivers enable a client computer to communicate with the machine via a printer language.

#### ❖ System requirements

Operating system

- Microsoft Windows 98SE
- Microsoft Windows Me
- Windows 2000
- Windows XP
- Windows Server 2003

Hard disk space

- 80 MB or more

---

### DDST TWAIN Driver

---

This driver is required for scanning originals on the machine.

You must install this driver to use the machine as a network TWAIN scanner.

#### ❖ System requirements

- Hardware  
PC/AT compatible
- CPU  
Pentium 300 MHz or faster recommended
- Operating system  
Microsoft Windows 98 (SE or later)  
Microsoft Windows Millennium Edition  
Microsoft Windows 2000 Professional  
Microsoft Windows 2000 Server  
Microsoft Windows XP Home Edition  
Microsoft Windows XP Professional
- Memory  
128 MB or more recommended
- Hard disk space  
200 MB or more
- Connection  
Ethernet/USB



# 3. Using the Printer Function

## Printer Features Menu

There are five menu items in the Printer Features menu:

### Reference

For more information about copier features and system settings, see *Copy Reference* and *General Settings Guide*.

- Paper Input
- List/Test Print
- Maintenance
- System
- Host Interface

You can select the following functions:

### ❖ Paper Input (See p.13 “Paper Input”)

Menu	Default
Bypass Paper Size	Metric version: A4 / Inch version: 11 × 8 <sup>1</sup> / <sub>2</sub>
Auto Paper Select	On
Duplex	On

### ❖ List/Test Print (See p.13 “List/Test Print”)

Menu	Default
Operations Test	—

### ❖ Maintenance (See p.14 “Maintenance”)

Menu	Default
Menu Protect	Off

### ❖ System (See p.15 “System”)

Menu	Default
Auto Continue	Off
Edge Smoothing	On
Toner Saving	Off

### ❖ Host Interface (See p.16 “Host Interface”)

Menu	Default
I/O Timeout	15 seconds

## Adjusting Printer Features

Use Printer Features to make basic adjustments when using the machine as a printer.

Although factory default settings are suitable for most print jobs, Printer Features allows you to access settings that control basic printer operations. The Printer Features settings you make are retained even after you turn off the machine.

For details about copier features and system settings, see *Copy Reference* and *General Settings Guide*.

3

**1** Press the **[User Tools/Counter]** key.

**2** Select **[Printer Features]** using the **[▲]** or **[▼]** key, and then press the **[OK]** key.



**3** Select the desired item using the **[▲]** or **[▼]** key, press the **[OK]** key, and then change its settings.



 **Note**

- [OK]**: Press to make new settings and go back to previous menus.
- [Escape]**: Press to return to a previous menu without changing any setting.

**4** After changing the Printer Features settings, press the **[User Tools/Counter]** key.

 **Note**

- Changes made to functions remain in effect even after you turn off the machine.

# Printer Features Parameters

## Paper Input

### ❖ Bypass Paper Size

The size of the paper set in the bypass tray.

#### Reference

For more information about paper sizes that can be set in the bypass tray, see *General Settings Guide*.

#### Note

Default:

- Metric version: A4
- Inch version: 11 × 8<sup>1</sup>/<sub>2</sub>

### ❖ Auto Paper Select

Set this to enable Auto Paper Select. The machine automatically detects the paper size from the print data, and selects a suitable paper feed tray accordingly.

#### Note

Default: On

### ❖ Duplex

You can set this to enable duplex printing. The machine detects duplex printing from the print data, and selects a suitable paper feed tray accordingly.

#### Note

Default: On

## List/Test Print

### ❖ Operations Test

You can print an operations test page.

### Printing the operations test page

#### 1 Press the [User Tools/Counter] key.

The User Tools main menu appears.

#### 2 Select [Printer Features] using the [▲] or [▼] key, and then press the [OK] key.



The Printer Features menu appears.

#### 3 Select [List/Test Print] using the [▲] or [▼] key, and then press the [OK] key.

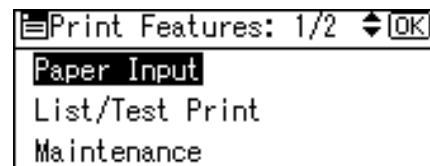

#### 4 Select [Operations Test] using the [▲] or [▼] key, and then press the [OK] key.

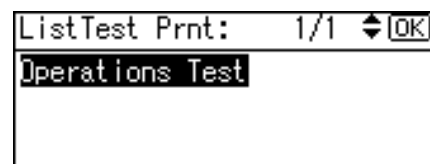

The operations test page is printed.

#### 5 Press the [User Tools/Counter] key.

## Maintenance

### ❖ Menu Protect

This procedure allows you to protect menu settings from accidental change. It makes it impossible to change menu settings with normal procedures unless you perform the required key operations.

- Level 1  
You can protect "Maintenance", "System", and "Host Interface".
- Level 2  
You can protect "Paper Input", "Maintenance", "System", and "Host Interface".
- Off

#### Note

- Default: Off

### Setting Menu Protect

#### 1 Press the [User Tools/Counter] key.

The User Tools main menu appears.

#### 2 Select [Printer Features] using the [▲] or [▼] key, and then press the [OK] key.



The Printer Features menu appears.

#### 3 Select [Maintenance] using the [▲] or [▼] key, and then press the [OK] key.

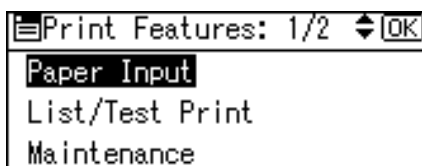

#### 4 Press [Menu Protect].

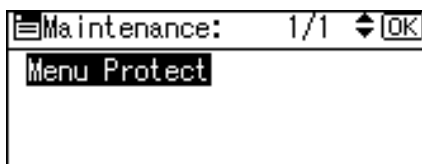

#### 5 Enter an access code using the number keys, and then press the [OK] key.

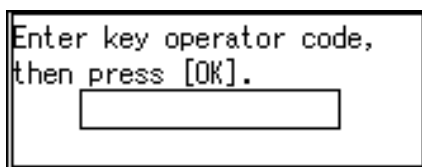

#### 6 Select a menu protect level, and then press the [OK] key.

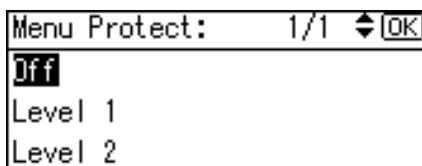

#### 7 Press the [User Tools/Counter] key.

### Canceling Menu Protect

#### 1 Press the [User Tools/Counter] key.

#### 2 Select [Printer Features] using the [▲] or [▼] key, and then press the [OK] key.

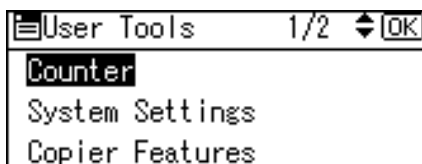

- 3** Select [Maintenance] using the [▲] or [▼] key, and then press the [OK] key.

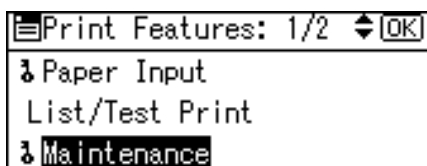

A screen for entering the access code appears.

- 4** Enter an access code using the number keys, and then press the [OK] key.

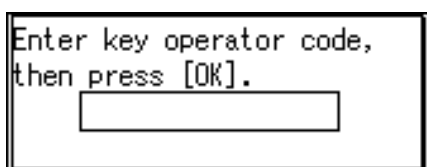

- 5** Press [Menu Protect].

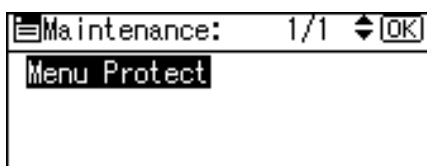

- 6** Enter an access code using the number keys, and then press the [OK] key.

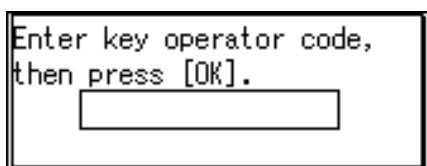

- 7** Select [Off], and then press the [OK] key.

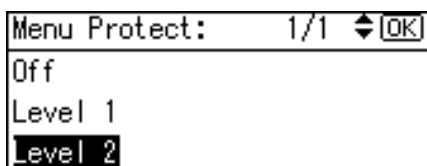

- 8** Press the [User Tools/Counter] key.

## Temporarily canceling Menu Protect

When you select protected items in Printer Features, a screen for entering the access codes appears. When this happens, enter the correct access codes using the number keys, and then press the [OK] key. Menu Protect is then temporarily canceled.

### Note

- If you enter a correct access code, Menu Protect is disabled as long as the Printer Features menu is displayed.

## System

### ❖ Auto Continue

You can select this to enable Auto Continue. When it is On, printing continues even if a system error occurs.

- Off
- 0 minutes
- 1 minute
- 5 minutes
- 10 minutes
- 15 minutes

### Note

- Default: *Off*

### ❖ Edge Smoothing

Set this to enable Edge Smoothing.

- On
- Off

### Note

- Default: *On*
- If Toner Saving is set to On, Edge Smoothing is ignored even if it is set to On.

### ❖ **Toner Saving**

Set this to enable Toner Saving.

- On
- Off

#### **Note**

Default: *Off*

---

## Host Interface

---

3

### ❖ **I/O Timeout**

You can set how many seconds the machine should wait before ending a print job. If data from another port usually arrives while an earlier job is printing out, increase the timeout period.

- 10 seconds
- 15 seconds
- 20 seconds
- 25 seconds
- 60 seconds

#### **Note**

Default: *15 seconds*

# Setting Paper on the Bypass Tray

The following explains setting paper on the bypass tray. Use the bypass tray to print onto OHP transparencies, labels, thick paper, and envelopes that cannot be loaded in the paper tray.

## Reference

For details about setting paper in the paper tray, see *General Settings Guide*.

## Note

- When loading letterhead paper, pay attention to its orientation. See "Orientation-Fixed Paper or Two-Sided Paper", *Copy Reference*.
- Paper within the following dimensions can be set in the bypass tray:
  - Vertical: 90.0-216.0 mm (3.54 in.- 8.50 in.)
  - Horizontal: 139.0-600.0 mm (5.47 in.-23.62 in.)
- Be sure to set the paper with the side you want to print facing down in the bypass tray.
- When loading OHP transparencies or thick paper in the bypass tray, make the paper setting using the control panel or printer driver.
- The number of sheets that can be loaded in the bypass tray depends on the paper type.

## Limitation

- The following functions are disabled when printing from the bypass tray:
  - Duplex Printing
  - Auto Tray Select
  - Auto Tray Switching

## Important

- When printing using the printer function, original images are always rotated by 180 degrees (the orientation of images to be printed is opposite to that of the copier function). When printing onto paper with specific orientation requirements, such as envelopes and letterheads, make sure to rotate the paper feed orientation by 180 degrees.
- Be sure to set the paper size using the printer driver when printing data from the computer. The paper size set using the printer driver has priority over the size set using the control panel.

## **1** Open the bypass tray.

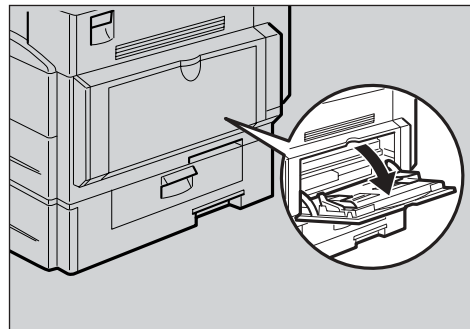

ARL0095

## **2** Adjust the paper guides to the paper size.

## Important

- If the paper guides are not flush against the paper, images might appear skewed and misfeeds could occur.

- 3** Gently insert paper face down into the bypass tray.

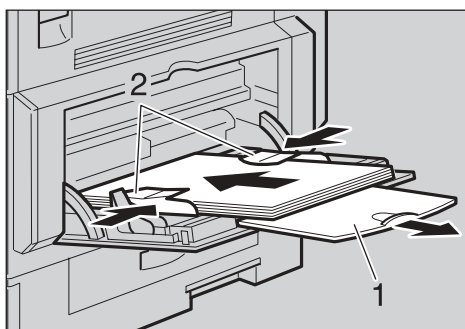

ABW020S1

1. Extender
2. Paper guides

**Note**

- Do not stack paper over the limit mark. If you do, images might appear skewed and misfeeds could occur.
- Fan the paper to get air between the sheets to avoid a multi-sheet feed.
- When setting an OHP transparency, make sure that its front and back sides are properly positioned.
- Select the paper type when printing onto OHP transparencies or thick paper (over 105g/m<sup>2</sup>). For details, see p.20 "Setting thick paper or OHP transparencies".
- Select the paper type when printing onto envelopes. For details, see p.21 "Setting envelopes".
- Set the paper size, see p.18 "Setting the paper size"

## Setting the paper size

**Note**

- You can set the paper size using the printer driver. The following procedures are not necessary when setting paper size using the printer driver.
- The paper size set using the printer driver has priority over the size set using the control panel.
- If you are not using the printer driver to make settings, use the control panel.

**Reference**

For printer driver settings, see the printer driver Help.

For details about setting custom sizes, see p.19 "Setting custom size paper".

- 1** Press the [User Tools/Counter] key.
- 2** Select [Printer Features] using the [▲] or [▼] key, and then press the [OK] key.



- 3** Select [Paper Input] using the [▲] or [▼] key, and then press the [OK] key.

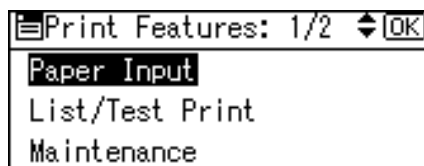



- 4** Select [Bypass Paper Size], and then press the [OK] key.

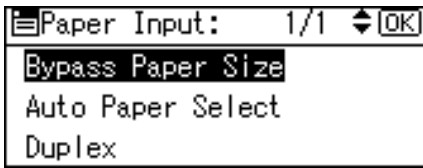

- 5** Select the paper size using the [▲] or [▼] key, and then press the [OK] key.

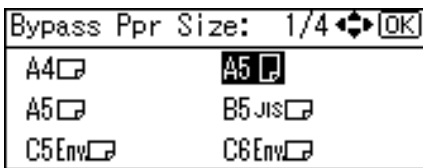

**Note**

- When printing onto thick paper or OHP transparencies, select the paper type. For details, see p.20 "Setting thick paper or OHP transparencies".

- 6** Press the [User Tools/Counter] key.

## Setting custom size paper

**Note**

- Custom sizes can also be set using the printer driver. The following procedures are not necessary when setting custom sizes using the printer driver.
- Custom size settings made using the printer driver have priority over those made using the machine's control panel.
- If you are not using the printer driver to make settings, use the control panel.

**Reference**

For printer driver settings, see the printer driver Help.

- 1** Press the [User Tools/Counter] key.

- 2** Select [Printer Features] using the [▲] or [▼] key, and then press the [OK] key.



- 3** Select [Paper Input] using the [▲] or [▼] key, and then press the [OK] key.

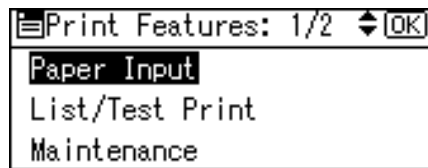

- 4** Select [Bypass Paper Size], and then press the [OK] key.

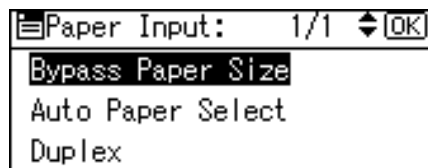

- 5** Select [Custom Size] using the [▲] or [▼] key, and then press the [OK] key.

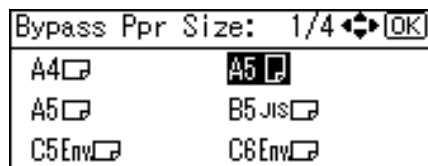

- 6** Enter the horizontal size of the paper using the number keys, and then press the [OK] key.

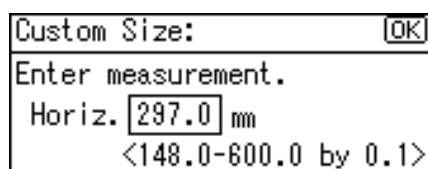

- 7** Enter the vertical size of the paper using the number keys, and then press the [OK] key.

Custom Size:	[OK]
Enter measurement.	
Vert.	210.0 mm
<90.0-297.0 by 0.1>>	

- 8** Press the [User Tools/Counter] key.

## Setting thick paper or OHP transparencies

### Note

- Paper settings can also be set using the printer driver. The following procedures are not necessary when setting paper sizes using the printer driver.
- Paper size settings made using the printer driver have priority over those made using the machine's control panel.
- If you are not using the printer driver to make settings, use the control panel.

### Reference

For printer driver settings, see the printer driver Help.

- 1** Press the [User Tools/Counter] key.
- 2** Select [System Settings] using the [▲] or [▼] key, and then press the [OK] key.

User Tools	1/2	[OK]
Counter		
System Settings		
Copier Features		

- 3** Select [Tray Paper Settings] using the [▲] or [▼] key, and then press the [OK] key.

System Settings	1/2	[OK]
General Features		
Tray Paper Settings		
Timer Settings		

- 4** Select [Paper Type:Bypass Tray] using the [▲] or [▼] key, and then press the [OK] key.

Tray/Paper	1/2	[OK]
Paper Size:Tray 1		
Paper Size:Tray 2		
Paper Type:Bypass Tray		

- 5** Select [OHP (Transparency)] or [Thick Paper] using the [▲] or [▼] key, and then press the [OK] key.

P. Type:Bypass	1/1	[OK]
No Display (Plain Paper)		
Thick Paper		
OHP (Transparency)		

- 6** Press the [User Tools/Counter] key.

### Note

- Settings remain valid until they are reset again. After printing on OHP transparencies or thick paper, make sure you clear settings for the next user.

## Setting envelopes

**1** Press the [User Tools/Counter] key.

**2** Select [System Settings] using the [▲] or [▼] key, and then press the [OK] key.

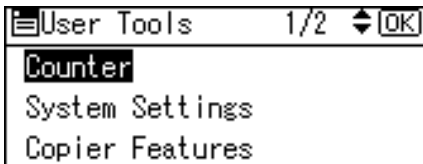

**3** Select [Tray Paper Settings] using the [▲] or [▼] key, and then press the [OK] key.

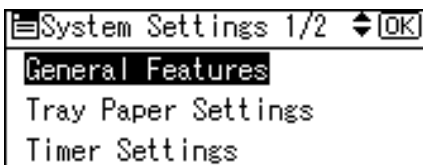

**4** Select [Paper Type:Bypass Tray] using the [▲] or [▼] key, and then press the [OK] key.

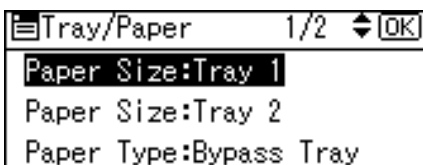

**5** Select [Thick Paper] using the [▲] or [▼] key, and then press the [OK] key.

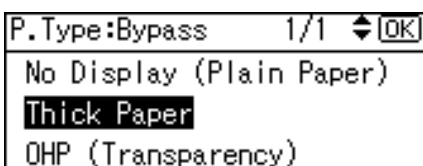

**6** Press the [Escape] key twice to return to the User Tools main menu.

**7** Select [Printer Features] using the [▲] or [▼] key, and then press the [OK] key.

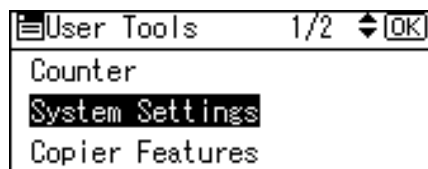

**8** Select [Paper Input] using the [▲] or [▼] key, and then press the [OK] key.

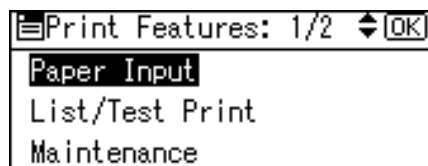

**9** Select [Bypass Paper Size], and then press the [OK] key.

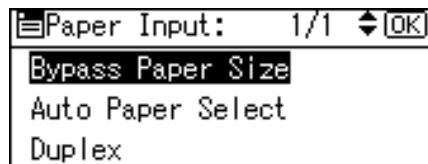

**10** Select the paper envelope size from [C6 Env], [C5 Env], or [DL Env], and then press the [OK] key.

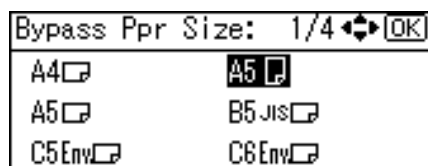

**11** Press the [User Tools/Counter] key.

# Setting Up the Printer Driver and Canceling a Print Job

## Windows 98SE / Me - Accessing Printer Properties

### Changing default settings

- 1** On the [Start] menu, point to [Settings], and then click [Printers].

The [Printers] window appears.

- 2** Click the icon of the machine whose default settings you want to change.

- 3** On the [File] menu, click [Properties].

The printer properties dialog box appears.

- 4** Make the settings you require, and then click [OK].

#### Note

- Settings made in some applications override settings made using the printer driver.

### Making settings from an application

To make settings for a specific application, use the printer properties dialog box inside that application. The following example describes how to make settings for the WordPad application that comes with Windows 98SE / Me.

#### Note

- Procedures for opening the printer properties dialog box vary depending on the application. For more information, see the operating instructions that come with the application you are using.
- Any settings you make in the following procedure are valid for the current application only.

- 1** On the [File] menu, click [Print].

The [Print] dialog box appears.

- 2** In the [Name] list, select the machine you want to use, and then click [Properties].

The printer properties dialog box appears.

- 3** Make the settings you require, and then click [OK].

- 4** Click [OK] to start printing.

## Windows 2000 / XP and Windows Server 2003 - Accessing Printer Properties

### Changing default settings - Printer properties

#### Limitation

- Changing machine settings requires Manage Printers permission. Members of Administrators and Power Users groups have Manage Printers permission by default. To set up options, log on using an account that has Manage Printers permission.

**1** On the [Start] menu, point to [Settings], and then click [Printers].

The [Printers] window appears.

#### Note

- Under Windows XP Professional and Windows Server 2003, open the [Printers and Faxes] window on the [Start] menu.
- Under Windows XP Home Edition, open the [Printers and Faxes] window by clicking [Control Panel] from the [Start] button on the taskbar, click [Printers and Other Hardware], and then click [Printers and Faxes].

**2** Click the icon of the machine whose default you want to change.

**3** On the [File] menu, click [Properties].

The printer properties dialog box appears.

**4** Make the settings you require, and then click [OK].

#### Note

- Settings you make here are used as the defaults for all applications.

### Changing default settings - Printing preferences properties

#### Limitation

- Changing machine settings requires Manage Printers permission. Members of the Administrators and Power Users groups have Manage Printers permission by default. To set up options, log on using an account that has Manage Printers permission.

**1** On the [Start] menu, point to [Settings], and then click [Printers].

The [Printers] window appears.

#### Note

- Under Windows XP Professional and Windows Server 2003, open the [Printers and Faxes] window on the [Start] menu.
- Under Windows XP Home Edition, open the [Printers and Faxes] window by clicking [Control Panel] from the [Start] button on the taskbar, click [Printers and Other Hardware], and then click [Printers and Faxes].

**2** Click the icon of the machine whose default settings you want to change.

**3** On the [File] menu, click [Printing Preferences...].

The [Printing Preferences] dialog box appears.

**4** Make the settings you require, and then click [OK].

**Note**

- ❑ Settings you make here are used as the defaults for all applications.

**Making settings from an application**

To make settings for a specific application, use the **[Print]** dialog box within that application. The following example describes how to make settings for the WordPad application that comes with Windows 2000 / XP and Windows Server 2003.

**Note**

- ❑ Procedures for opening the **[Print]** dialog box vary depending on the application. For details, see the operating instructions that come with the application you are using.
- ❑ Any settings you make in the following procedure are valid for the current application only.

**1** On the **[File]** menu, click **[Print...]**.

The **[Print]** dialog box appears.

**2** In the **[Select Printer]** list, select the machine you want to use, and then click the tab that contains the print settings you want to change.**Note**

- ❑ Under Windows XP and Windows Server 2003, click **[Preference]** to open the Printing Preferences dialog box.

**3** Make the settings you require.**4** Click **[Print]** to start printing.

Under Windows XP and Windows Server 2003, click **[OK]**, and then click **[Print]** to start printing.

**Canceling a Print Job****1** Double-click the printer icon on the Windows taskbar.

A window appears, showing all print jobs currently queued for printing. Check the current status of the job you want to cancel.

**2** Select the name of the job you want to cancel.**3** On the **[Document]** menu, click **[Cancel Printing]**.**Note**

- ❑ Under Windows 2000 / XP, and Windows Server 2003, click **[cancel]** on the **[Document]** menu.
- ❑ Under Windows 98SE / Me / 2000 / XP, or Windows Server 2003, you can also open the print job queue window by double-clicking the machine icon in the **[Printers]** machine window (the **[Printers and Faxes]** window under Windows XP and Windows Server 2003).

**4** Press the **[Printer]** key.**5** Press **[JobReset]**.

**6** Press **[Current]**.

- **[Current]**: cancels the print job currently being processed.
  - **[Resume]**: resumes printing jobs.
- A confirmation message appears.

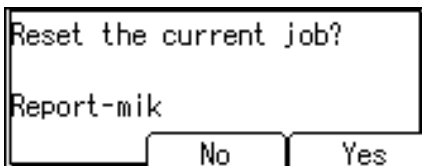
**7** Press **[Yes]** to cancel the print job. **Note**

- Press **[No]** to return to the previous display.

 **Important**

- If the machine is shared by multiple computers, be careful not to accidentally cancel someone else's print job.

 **Note**

- You cannot stop printing data that has already been processed. For this reason, printing may continue for a few pages after you press **[JobReset]**.
- Data-heavy jobs may take considerable time to stop.





# 4. Using the TWAIN Scanner Function

## TWAIN Scanner

Client computers can use this machine as a network TWAIN scanner.

Using direct USB connection, stand alone computers can also use this machine as a TWAIN scanner.

Procedures for network scanning are the same as those for scanning via USB connection.

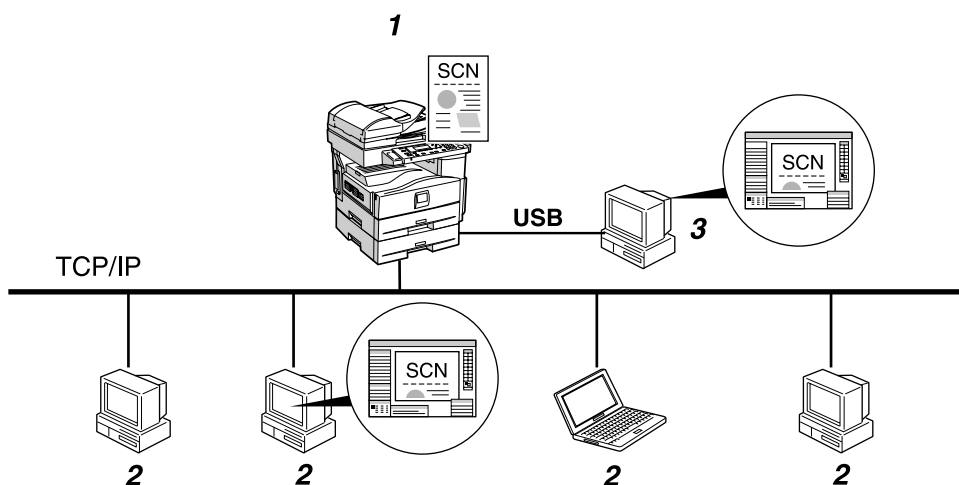

ARL013S

### 1. This machine

Connects to computers via Ethernet (TCP/IP) and/or USB.

### 2. Client computer

Uses the scanner via a TWAIN-compliant application (such as Imaging).

### 3. Stand-alone computer

Uses the scanner via direct USB connection and a TWAIN-compliant application (such as Imaging).

---

## Process Flow

---

- 1** Scanning commands are sent to the machine (1.) via the TWAIN driver from a TWAIN-compliant application installed on the client (2.) or stand-alone (3.) computer.
- 2** The machine (1.) scans the originals.
- 3** Scanned data is edited and stored using the TWAIN-compliant application on the client (2.) or stand-alone (3.) computer.

# Preparation for Using the Network TWAIN Scanner

The following diagram shows the preparation required to use this machine as a TWAIN scanner.

Install the TWAIN driver on a client computer. \*1

See p.9 "Installing the TWAIN Driver".



Connect the scanner and client computer with a cable.

USB connection: See p.5 "Connecting the machine to the host using a USB cable".  
Ethernet connection: See "Connecting the Machine" in *Network Guide*.

4

\*1 To you use this machine as a TWAIN scanner, you must be running a TWAIN-compliant application on a client computer.

---

## TWAIN Scanner Screen

---

When using the machine as the TWAIN scanner, it is not necessary to press the **[Scanner]** key on the control panel. When the TWAIN driver becomes active, the display automatically switches to the following screen:

```
Connecting with PC.  
Set originals and select  
the settings from PC.
```

# Setting Originals



The following explains the procedure for placing originals on the exposure glass and in the ARDF, and setting the scan area and orientation according to how you have set your originals.

To correctly display the top/bottom orientation of the scanned original on a client computer, the placement of the original and the settings made on the control panel and scanner driver must match.



## Placing Originals

Place originals in one of the two orientations show in the table below.

### Note

- Normally, an original is  or , but the table below uses a square original to make orientation easier to understand. Even if the shape of your original is different to that shown in the table, the combination of original orientation and the orientation specified on the control panel or scanner driver does not change.

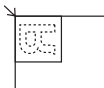
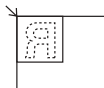
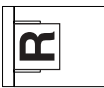
### ❖ Specifying original orientation and setting originals

<b>1</b> An original to be scanned				
<b>2</b> Decide the placement method.	Exposure glass		ARDF	
<b>3</b> Place the original. (There are two original orientations.)	Place the original so that the top edge touches the top left of the exposure glass.  	Place the original so that the top edge touches the rear of the exposure glass.  	Place the top edge of the original first.  	Place the original so that the top edge touches the back of the ARDF.  
<b>4</b> The original displayed on a computer				

### Placing on the Exposure Glass

Originals that do not fit into the ARDF, such as sheets with glued-on parts, books, etc., can be placed directly on the exposure glass for scanning.

**Note**

- ❑ For details about originals that you can place on the exposure glass, see *Copy Reference*.

**1** Lift the exposure glass cover or the ARDF.

**Note**

- ❑ Lift the exposure glass cover or ARDF to an angle of more than 30 degrees. The opening/closing action triggers the automatic original size detection process.

**2** Place the original on the exposure glass with the side to be scanned facing down. Align the original with the back left corner mark.

There are two original orientations.

- ❖ When placing the original so that the top edge touches the rear of the exposure glass

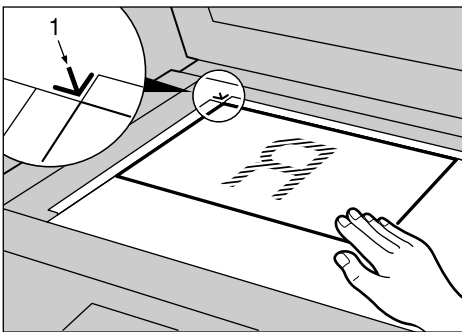

ABF007S

**1. Positioning mark**

- ❖ When placing the original so that the top edge touches the top left of the exposure glass

When using the machine as a network TWAIN scanner, this orientation is the standard setting for the TWAIN driver. This orientation is suitable for most originals.

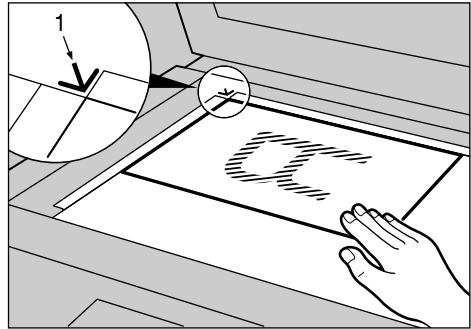

ABF008S

**1. Positioning mark**

**3** Lower the exposure glass cover or the ARDF.

**4** Select the original orientation according to the orientation of the placed original.

**Reference**

p.29 "Specifying original orientation and setting originals"

## Placing in the Auto Document Feeder

The ARDF allows you to place multiple originals at once. Originals placed in the ARDF can be scanned on one side or both sides.

### ❖ Originals that can and cannot be placed in the ARDF

For details about originals that you can place in the ARDF, see *Copy Reference*.

Attempting to feed unsuitable originals into the ARDF can result in misfeeds and damage to the originals. Place such originals directly on the exposure glass.

### ⚠ Important

- For information about placing originals in the ARDF, see *Copy Reference*.

### 1 Adjust the original guide to match the size of the originals.

### 2 Place the originals with the side to be scanned facing up.

To scan both sides of an original, place the original so that its first side is face up.

There are two orientations.

### ❖ When placing the originals so that the top edges touch the back of the ARDF

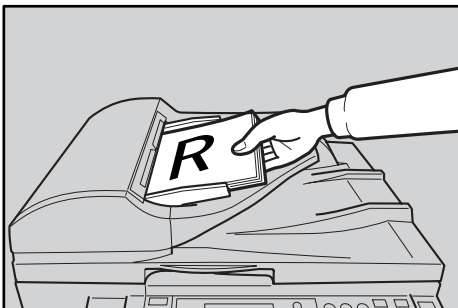

ARL011S

### ❖ When placing the top edges of the originals first

When using the machine as a network TWAIN scanner, this orientation is the standard setting for the TWAIN driver. This orientation is suitable for most originals.

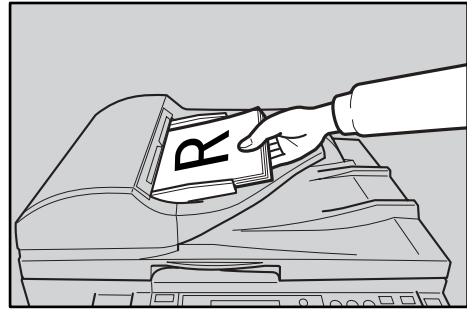

ARL012S

### 3 Select the original orientation according to the orientation of the placed originals.

### 🔍 Reference

p.29 "Specifying original orientation and setting originals"

## Scanning Originals

This section explains how to scan originals using the TWAIN scanner function. This procedure explains scanning originals using Imaging under Windows 2000.

**1** Start **Imaging**, and then select the scanner driver.

**2** On the **[Start]** menu, point to **[Program]**, point to **[Accessories]**, and then click **[Imaging]**.

**3** Click **[Select Device...]** on the **[File]** menu.

If the scanner is already selected, no scanner settings are necessary. Proceed to step **5**.

**4** Select the name of the machine you want to use in the list, and then click **[OK]**.

**5** Place the original in the scanner.

### Reference

p.29 "Placing Originals"

**6** Click **[Acquire Image...]** on the **[File]** menu.

The TWAIN Driver dialog box appears.

**7** Select the connection method.

If you are using Network TWAIN, enter the IP address in the box under **[Select Device]**.

If you are using USB TWAIN, click the **[USB]** check box.

**8** Click **[OK]**.

The Main Settings window appears.

**9** Click **[Preview]** or **[Scan]** to preview or scan the image.

Click **[Scan]** to return to Imaging.

**10** Save the scan file in Imaging.

**11** On the **[File]** menu, click **[Save]**.

**12** Enter the file name, select the folder in which you want to save the file, and then click **[Save]**.

For details about the scanning function, click **[Help]** in the Main Settings dialog box.

# 5. Troubleshooting

## The Printer Function

---

### Error & Status Messages on the Display

---

This section describes the principal messages that appear on the display. If a message that is not described here appears, follow its instructions.

#### Reference

Before turning the main power off, see 'Turning On the Power', *Copy Reference*.

#### ❖ Status messages

Message	Status
Offline	The machine is offline. To start printing, switch the machine online by pressing <b>[Online]</b> on the control panel.
Please wait.	Wait a while.
Printing...	The machine is printing. Wait a while.
Waiting...	The machine is waiting for the next data to print. Wait a while.
Ready	The machine is ready for use. No action is required.
Resetting Job...	The machine is resetting the print job. Wait until "Ready" appears on the display.
Setting change...	The machine settings are being changed. Wait a while.

#### ❖ Alert messages

Messages/Second messages	Causes	Solutions
Change Tray # to the following settings: xxx yyy	The settings of the selected paper tray are different from those specified for printing. # indicates the tray number. xxx indicates the tray number. yyy indicates the paper size.	Press <b>[JobReset]</b> to change the paper tray settings, or press <b>[FormFeed]</b> to print regardless. For details about the paper tray settings, see <i>General Settings Guide</i> .
Collate cancelled.	The collate print function has been canceled.	Turn the main power switch off, wait a few seconds, and then turn it back on. If the message appears again, contact your sales or service representative.

Messages/Second messages	Causes	Solutions
Collate: Page max.	The maximum number of pages has been exceeded for collation.	Turn the main power switch off, wait a few seconds, and then turn it back on. Reduce the number of pages to be printed, or, increase memory capacity. To install a memory module in the machine, contact your sales or service representative.
Duplex cancelled.	Duplex printing has been canceled.	Check the paper used is suitable for duplex printing, or, increase memory capacity. To install a memory module in the machine, contact your sales or service representative.
Duplex mode is in off position for Tray #	The selected paper tray has not been configured for duplex printing. # indicates the tray number.	Press <b>[JobReset]</b> to change the paper tray settings or do single-sided printing. For details about tray settings, see <i>General Settings Guide</i> .
Ethernet Board Error	An error has occurred in the Ethernet interface.	Turn the main power switch off, wait a few seconds, and then turn it back on. If the message appears again, contact your sales or service representative.
Exceeded max. print size. Press FormFeed/JobReset.	The page images to be printed exceed the maximum print area.	Press <b>[JobReset]</b> to change the paper tray settings, or press <b>[FormFeed]</b> to print regardless.
I/O buffer overflow	The maximum size of the I/O buffer has been exceeded.	Increase the size of the I/O buffer through the Host Interface menu.
Load paper in Tray #	There is no paper in the selected paper tray. # indicates the tray number.	Load the tray with paper.
NV-RAM Error	An error has occurred in the printer.	Turn the main power switch off, wait a few seconds, and then turn it back on. If the message appears again, contact your sales or service representative.
Output Tray changed.	The output tray has been changed due to the paper size limitation of the selected tray.	Select the correct output tray.



Messages/Second messages	Causes	Solutions
Paper size/type mismatch. Change settings to: xxx yyy	There is no paper tray that matches the paper settings selected under Auto Tray Select. xxx indicates the tray number. yyy indicates the paper size and the paper type.	Press <b>[JobReset]</b> to change the paper tray settings, or press <b>[FormFeed]</b> to print regardless. For details about paper tray settings, see <i>General Settings Guide</i> .
[Print] without below mode?	This is an alert message concerning a paper tray in auto tray select.	Press <b>[Print]</b> to cancel the mode and print the job.
Printer Font Error	An error has occurred in the font file.	Turn the main power switch off, wait a few seconds, and then turn it back on. If the message appears again, contact your sales or service representative.
Print overrun.	Image compression has resulted in image degradation.	Increase memory capacity. To install a memory module in the machine, contact your sales or service representative.
Paper Tray is in use.	The specified paper tray is in use by another function, such as the copier function.	Wait until the other function has finished using the specified paper tray.
Reset Paper Tray correctly.	The selected paper tray does not exist or is not set correctly.	Set the paper tray correctly.
 Toner is almost empty Add toner	Toner is running out.	Replace the toner cartridge soon to maintain print quality.
Tray # Error	A paper tray error has occurred. # indicates the tray number.	Press <b>[JobReset]</b> to change the paper tray settings, or press <b>[FormFeed]</b> to select another paper tray and print.
Unauthorized user access.	Print job canceled due to user restrictions.	Check the User Code permission status.
USB has a problem	An error has occurred in the USB interface.	Turn the main power switch off, wait a few seconds, and then turn it back on. If the message appears again, contact your sales or service representative.

## The Machine Does Not Print

Possible Cause	Solutions
Is the power on?	Check the cable is securely plugged into the power outlet and the machine. Turn on the main power switch.
Is the machine online?	If not, press <b>[ ⏪ Online ]</b> on the control panel.
Does the Printer key stay red?	If so, read the error message on the display and take the required action.
Is there a warning status or error message on the display?	If so, read the error message or warning status on the display and take the required action.
Is the interface cable connected securely to the machine and computer?	Connect the interface cable securely. If it has a fastener, fasten that securely as well. See p.5 "Connecting the Machine".
Are you using the correct interface cable?	The type of interface cable you should use depends on the computer. Be sure to use the correct one. If the cable is damaged or worn, replace it. See p.5 "Connecting the Machine".
Was the interface cable connected after the machine was turned on?	Connect the interface cable <i>before</i> turning on the machine.

Problem	Solutions
<p>Is the <b>Data In</b> indicator blinking or lit after starting the print job?</p>	<p>If not, data is not being sent to the machine.</p> <ul style="list-style-type: none"> <li>❖ <b>If the machine is connected to the computer using the interface cable</b> <p>Check the machine port settings are correct. For USB port connection, the USB port must be set.</p> <ul style="list-style-type: none"> <li>• <b>Windows 98SE / Me</b> <ol style="list-style-type: none"> <li>① Click the <b>[Start]</b> button, point to <b>[Settings]</b>, and then click <b>[Printers]</b>.</li> <li>② Click the icon of the machine. On the <b>[File]</b> menu, click <b>[Properties]</b>.</li> <li>③ Click the <b>[Details]</b> tab.</li> <li>④ In the <b>[Print to the following port:]</b> list, confirm the correct port is selected.</li> </ol> </li> <li>• <b>Windows 2000</b> <ol style="list-style-type: none"> <li>① Click the <b>[Start]</b> button, point to <b>[Settings]</b>, and then click <b>[Printers]</b>.</li> <li>② Click the icon of the machine. On the <b>[File]</b> menu, click <b>[Properties]</b>.</li> <li>③ Click the <b>[Ports]</b> tab.</li> <li>④ In the <b>[Print to the following port(s)]</b> list, confirm the correct port is selected.</li> </ol> </li> <li>• <b>Windows XP Professional and Windows Server 2003</b> <ol style="list-style-type: none"> <li>① Click the <b>[Start]</b> button, and then click <b>[Printers and Faxes]</b>.</li> <li>② Click the icon of the machine. On the <b>[File]</b> menu, click <b>[Properties]</b>.</li> <li>③ Click the <b>[Ports]</b> tab.</li> <li>④ In the <b>[Print to the following port(s)]</b> list, confirm the correct port is selected.</li> </ol> </li> <li>• <b>Windows XP Home Edition</b> <ol style="list-style-type: none"> <li>① Click the <b>[Start]</b> button, click <b>[Control Panel]</b>, click <b>[Printers and Other Hardware]</b>, and then click <b>[Printers and Faxes]</b>.</li> <li>② Click the icon of the machine. On the <b>[File]</b> menu, click <b>[Properties]</b>.</li> <li>③ Click the <b>[Ports]</b> tab.</li> <li>④ In the <b>[Print to the following port(s)]</b> list, confirm the correct port is selected.</li> </ol> </li> </ul> </li> <li>❖ <b>Network connection</b> <p>Contact your network administrator.</p> </li> </ul>

## Other Printing Problems

Problem	Causes and Solutions
Smudged print.	<p>You are printing on thick paper, but thick paper settings have not been made.</p> <p>Select <b>[Thick]</b> in the <b>[Type:]</b> list on the <b>[Paper]</b> tab on the printer driver.</p>
Page layout is not as expected.	<p>Print areas differ depending on the machine used. Information that fits on a single page on one machine may not fit on a single page on another machine.</p>
Duplex printing is not possible.	<ul style="list-style-type: none"> <li>• Duplex printing cannot be done with paper set in the bypass tray. To use duplex printing, specify a paper tray other than the bypass tray.</li> <li>• Duplex printing is not possible if thick paper, OHP transparencies, or label paper is specified as the paper type. Specify another paper type.</li> <li>• Duplex printing cannot be done using a tray for which <b>[Duplex]</b> is not selected as the paper type in <b>[Tray Paper Settings]</b> in <b>[System Settings]</b>. Select <b>[Duplex]</b> as the paper type in <b>[Paper Input]</b>. See <i>General Settings Guide</i>.</li> </ul>
When using Windows 98SE / Me or Windows 2000 / XP, either combined printing or booklet print does not come out as expected.	<p>Make sure the application's paper size and orientation settings match those of the printer driver.</p> <p>If a different paper size and orientation are set, select the same size and orientation.</p>
When using Windows 98SE / Me or Windows 2000 / XP, Auto Reduce/Enlarge print does not come out as expected.	
A print instruction was issued from the computer, but printing did not start.	<p>User code management may be set. Ask the administrator about valid user codes. To print, the user code must be entered from the printer driver.</p>
The print job is not canceled even when the machine is switched to off-line status.	<p>Select <b>[Printer Priority]</b> for <b>[Signal Control]</b>.</p> <p>See "User Tools (System Settings)", <i>General Settings Guide</i>.</p>
Photo images are coarse.	<p>Some applications reduce print resolution. Check your application.</p>
Images are cut off, or excess is printed.	<p>You may be using paper smaller than the size selected in the application. Use the same size paper as that selected in the application. If you cannot load paper of the correct size, use the reduction function to reduce the image, and then print.</p>

Problem	Causes and Solutions
It takes a long time to complete a print job.	Data-heavy print jobs require time to process. If the <b>Data In</b> indicator is blinking, data is being processed. Wait until printing resumes.
It takes too much time to resume printing.	Data-heavy print jobs require time to process. If the <b>Data In</b> indicator is blinking, data is being processed. Wait until printing resumes.
	The machine is in Energy Saver mode. To resume from Energy Saver mode, it has to warm up, and this takes time. See <i>General Settings Guide</i> .
Paper is not fed from the selected tray.	Under Windows operating systems, printer driver settings override those set using the control panel. Set the desired input tray using the printer driver.
Optional components connected to the machine are not recognized when using Windows 98SE / Me, Windows 2000 / XP, and Windows Server 2003.	You have to configure the option setup in printer properties when bi-directional transmission is not enabled. See the printer driver Help.
Images are printed in the wrong orientation.	The feed orientation you selected and the feed orientation selected in the printer driver's option setup might not be the same. Set the machine's feed orientation and the printer driver's feed orientation accordingly. See the printer driver Help.
The printed image is different from the image on the computer's display.	With certain functions, such as enlargement and reduction, image layout might be different to that shown on the computer display.

 **Note**

- If the problem cannot be solved, contact your sales or service representative.

# The Scanner Function

## When Scanning Is Not Performed as Expected

Problems	Causes and solutions
Scanning fails to generate an image.	The original is placed wrong side down. Place originals face down on the exposure glass; face up in the ARDF. See p.29 "Placing Originals".
The image is distorted or out of position.	<ul style="list-style-type: none"> <li>• The original was moved during scanning. Do not move the original during scanning.</li> <li>• The original is not flat against the exposure glass. Make sure it is pressed flat against the exposure glass.</li> </ul>
The scanned image is dirty.	The exposure glass or the exposure glass cover is dirty. Clean these parts. See <i>General Settings Guide</i> .
The scanned image is upside down.	The original is placed upside down. Place it in the correct orientation. See p.29 "Placing Originals".

## When an Error Message Appears on the Client Computer

This section describes possible causes and actions for common error messages displayed on the client computer when using the TWAIN driver.

### Note

- If an error message not detailed in this section appears, turn off the machine's main power switch, wait a few seconds, and then turn it on again. If the message reappears after scanning is performed again, make a note of the message and the error number (if it is listed in the table), and contact your service representative. For details about how to turn off the main power switch, see *General Settings Guide*.

Message	Causes and solutions
[Clear Misfeed(s) in ADF.]	Remove jammed originals. Check the originals are suitable for scanning, and if they are, place them again.
[Insufficient memory. Close all other applications, then restart scanning.]	Close all unnecessary applications running on the client computer.
[Insufficient memory. Reduce the scanning area.]	<ul style="list-style-type: none"> <li>• Reset the scan size.</li> <li>• Lower the resolution.</li> </ul> <p> <b>Note</b></p> <ul style="list-style-type: none"> <li><input type="checkbox"/> If a misfeed occurs during printing, scanning cannot be performed. If this happens, remove any misfed paper, and then proceed with scanning.</li> </ul>
[Scanning has been aborted.]	<p>Check the machine's power switch is turned on.</p> <p>Check the machine is connected to the network correctly.</p>
[No original on exposure glass.]	<p>Place the original correctly.</p> <p>See p.29 "Placing Originals".</p>
[No response from the scanner.]	<ul style="list-style-type: none"> <li>• Check the machine is connected to the network correctly.</li> <li>• The network is busy. Wait for a while, and then try to reconnect.</li> </ul>
[Scanner is in use by other user. Please wait.]	The scanner function is being used. Wait for a while and reconnect.
[Scanner is not available. Check the scanner connection status.]	<ul style="list-style-type: none"> <li>• Check the machine's power switch is turned on.</li> <li>• Check the machine is connected to the network correctly.</li> <li>• Disable any firewalls that are running on the client computer.</li> </ul>





## The Printer Function

---

### Collate

---

If you select the collate function on the printer driver, the machine will store print data in memory and automatically collate the printouts.

The collate function can be turned on or off from the printer driver.

⚠ **Limitation**

You cannot use the bypass tray with this function.

❖ **Collate**

Orders output into sequential sets.

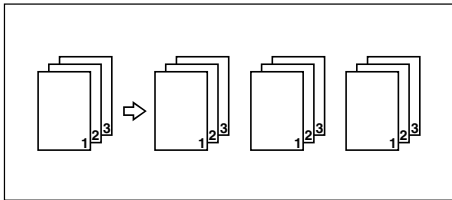

# The Scanner Function

---

## Relationship between Resolution and File Size

---

Resolution and scan area are inversely related. The higher the resolution is set, the smaller the area that can be scanned. Similarly, the larger the scan area, the lower the resolution that can be set.

The relationship between scanning resolution and file size is shown below. If the file size is too large, the message "Exceeded max.data capacity. Check the scanning resolution." appears on the machine's control panel, and you must specify the scan size and resolution again.

### **Limitation**

- Maximum image size is limited according to the level of compression.

---

### When Using as a TWAIN Scanner

---

All combinations up to 216 × 356 mm / 8.5 × 14.0 inches (A4, 8<sup>1</sup>/<sub>2</sub> × 14 inches) and 600 dpi are possible.

### **Reference**

To specify the scanning area or resolution when using the machine as a network TWAIN scanner, see TWAIN driver Help.

# Specifications

## Printer

This section details the machine's electrical and hardware specifications, including information about its options.

Component	Specifications
Resolution	600 dpi
Printing speed	16 ppm (A4, 8 <sup>1</sup> / <sub>2</sub> " × 11" plain paper)
Interface	USB 2.0 interface Ethernet interface (100BASE-TX/10BASE-T)
Network protocol	TCP/IP IPP
Printer language	Host-Based Printing
Memory	64 MB
Operating systems supported by this machine	Windows 98SE / Me Windows 2000 Windows XP Windows Server 2003
Required network cable	100BASE-TX/10BASE-T shielded twisted-pair (STP, Category/Type5) cable.

6

## Scanner

Scan method	Flatbed scanning
Scan speed <sup>*1</sup>	Approx. 18 pages/minute [Scan size: A4, Colours/Gradients: Binary, Resolution: 200dpi, Select device data compression (Binary/Halftone): Data compression (MMR), Document feeder: ARDF, ITU-T No.1 Chart]
Maximum power consumption	Less than 900 W
Image sensor type	CCD Image Sensor
Scan types	Sheet, book
Interface	USB interface, Ethernet interface (10BASE-T or 100BASE-TX)
Maximum scan size	216 × 356 mm/8.5 × 14.0 inches (A4, 8 <sup>1</sup> / <sub>2</sub> × 14 inches)
Resolution	600 dpi
Variable range of scan resolution	Setting range: 100 dpi - 600 dpi

<sup>\*1</sup> Scanning speeds vary according to machine operating conditions, computer (specification, network traffic, and software, etc.), and original types.

# INDEX

## B

---

Bypass tray, 17

## C

---

Canceling a job, 24

Connection

*Ethernet board connection, 5*

*USB connection, 5*

Control Panel, 3

Custom size paper, 19

*printing, bypass tray, 17*

## D

---

Data In indicator, 37, 39

DDST TWAIN Driver, 10

Display, 4

*error messages, 33*

## E

---

Error messages, 33

## H

---

Host Interface, 16

## I

---

Interface, 45

## L

---

List/Test Print, 13

## M

---

Maintenance, 14

Memory, 45

## N

---

Network Cable, 45

Network protocol, 45

## O

---

OHP Transparencies

*printing, bypass tray, 20*

Operating system, 45

Operations Test, 13

## P

---

Paper Input, 13

paper size, 18

Placing Originals, 29

*Placing on the exposure glass, 30*

*Placing original in the*

*Auto Document Feeder (ARDF), 31*

Printer driver

DDST, 10

*Printer properties, Windows 2000 / XP  
and Windows Server 2003, 23*

*Printer properties, Windows 98SE / Me, 22*

printer driver

*Auto Run, 7*

*installing, 8*

Printer Features

*adjusting, 12*

*menu, 11*

*parameters, 13*

Printer Language, 45

Printing speed, 45

## R

---

Relationship between resolution and file size, 44

*When Using as a TWAIN Scanner, 44*

Resolution, 45

## S

---

Scanning originals, 32

Setting Originals, 29

Software supplied on CD-ROM, 10

Specifications, 45

System, 15

## T

---

Thick Paper

*printing, bypass tray, 20*

Troubleshooting, 33

*error messages, 33*

*machine does not print, 36*

*other printing problems, 38*

*status messages, 33*

*When an Error Message Appears  
on the Client Computer, 41*

*When Scanning Is*

*Not Performed as Expected, 40*

TWAIN

*installing, 9*

TWAIN scanner, 27

## **W**

---

- Windows 2000 / XP and Windows Server 2003
  - printer properties, printer driver, 23*
- Windows 98SE / Me
  - printer properties, printer driver, 22*





Declaration of Conformity

“The Product complies with the requirements of the EMC Directive 89/336/EEC and its amending directives and the Low Voltage Directive 73/23/EEC and its amending directives.”



**Caution:**

Network interface cables with ferrite core must be used for RF interference suppression.



